



Leading R&D capability



Superior Quality



Advanced manufacturing capability



Fast service capability



High Energy Saving Industrial Fan Catalog

Permanent Magnet Direct Drive Motor (PMSM)



WANSHSIN®

WANSHSIN SEIKOU(HUNAN)CO.,LTD

Tel: +86-731-84221213

Email: sales@wanshsin.com

Website: www.wanshsin.com

Add: WANSHSIN Industrial Park,Ningxiang

High-Tech District,Changsha City,Hunan Province.China



To build the world production base of industrial HVLS Ceiling fan

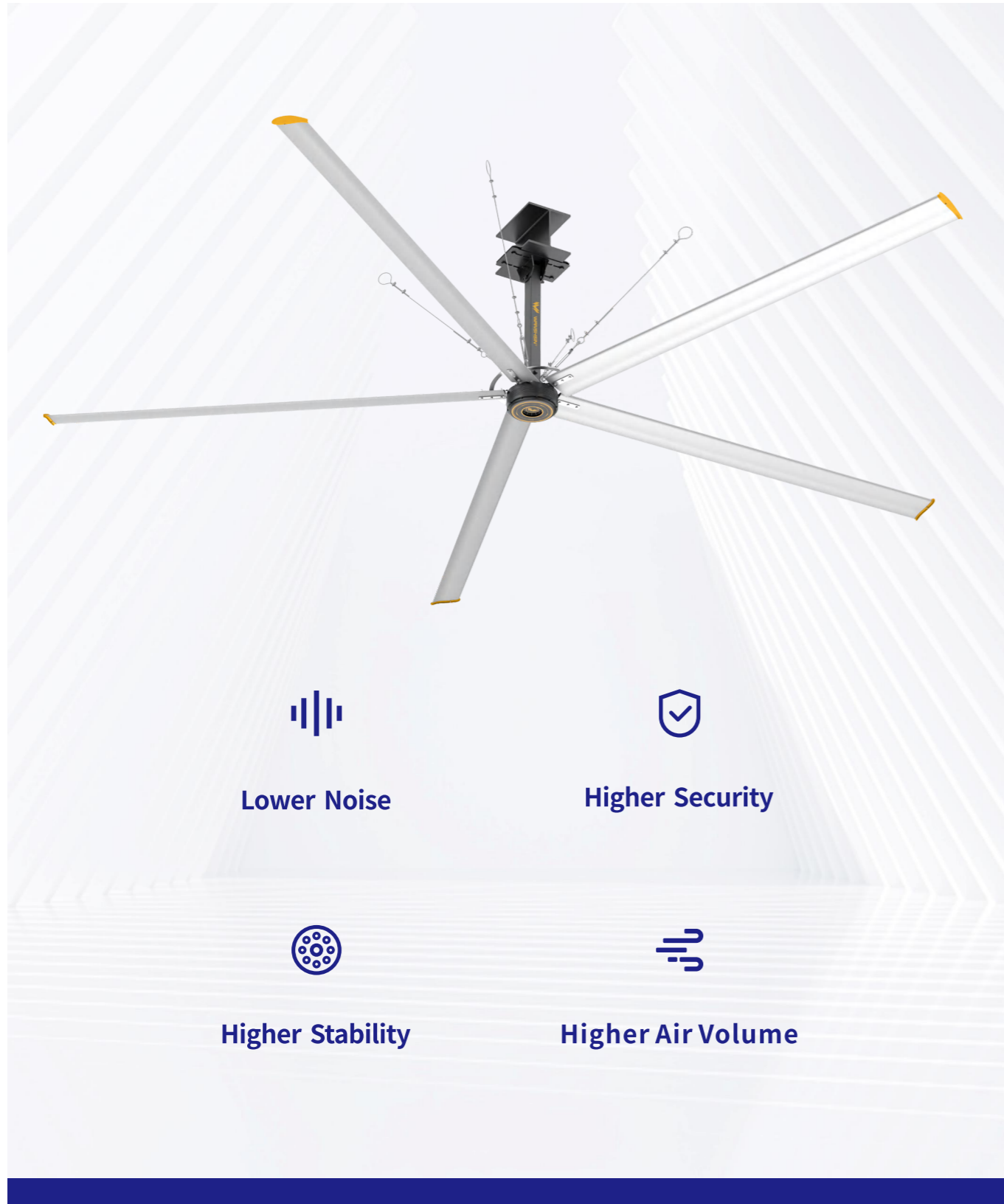

CONTENTS

01-02	Company Profile
03-07	HVLS Ceiling Fan Characteristics Industrial HVLS Ceiling Fan (Outer Rotor PMSM)
08	Control System
09-12	Safety Guarantees
13	Optional Accessories
14	Structure
15-16	Applications
17	PMSM Exhaust Fan
18-19	DC Brushless Permanent Magnet Motor
20	Applications

WANSHSIN SEIKOU(HUNAN) CO., LTD.



WANSHSIN was founded in 2009 in Dongguan, Guangdong, and relocated its headquarters to Changsha, Hunan, in 2014. Currently, the company has 5 production bases in Dongguan, Changsha, and Zhuzhou, as well as 3 major R&D centers in its Hunan headquarters, Japan, and Shenzhen, leading the industry's high-quality development through innovation.

WANSHSIN is the only company in the country specializing in the R&D of integrated electromechanical control systems. It is also a professional manufacturer of gearboxes, gear motors, and inverters, offering comprehensive solutions in intelligent automation that encompass R&D, production, sales, and service. Its products cover both light and heavy industries and have been widely applied in sectors such as renewable energy, robotics, automation, intelligent warehousing, logistics, and food processing. WANSHSIN has gradually become a long-term partner of major leading enterprises in the industry.

Core Competitiveness



Leading R&D Capability

3 R&D Centers, Leading the high-quality development of the industry with innovation.

Excellent Quality

WANSHSIN is the first company in the industry to launch advanced product quality planning for the automobile industry; it has equipped a large number of imported internationally advanced inspection/testing equipments to ensure product quality.

Advanced Manufacturing

It has hundreds of domestic and foreign advanced processing equipments with a total value of over USD 25 million, and its manufacturing capabilities are in a leading position in the country.

Industrial HVLS Ceiling Fan Characteristics

Ventilation Theory

- Three-Dimensional Natural Breeze
- large Circulation Natural Ventilation
- Optimal Air Setting Position
- Dehumidification and Moisture-Proof
- Cool down 8 ° C

Ventilation Air Flow Direction

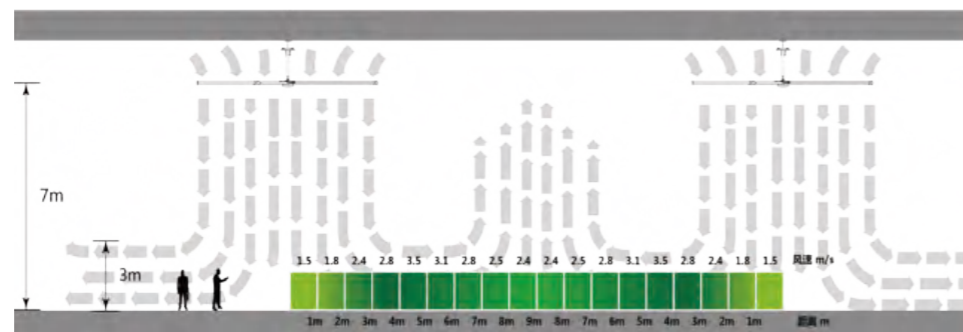
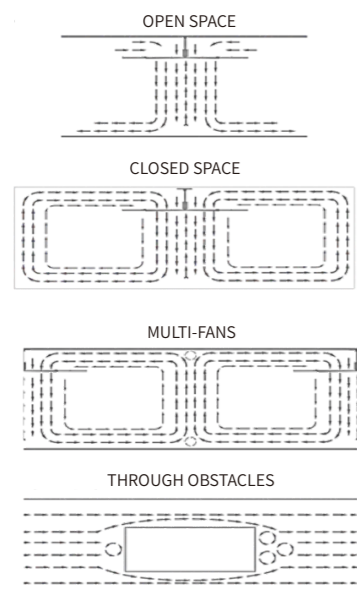
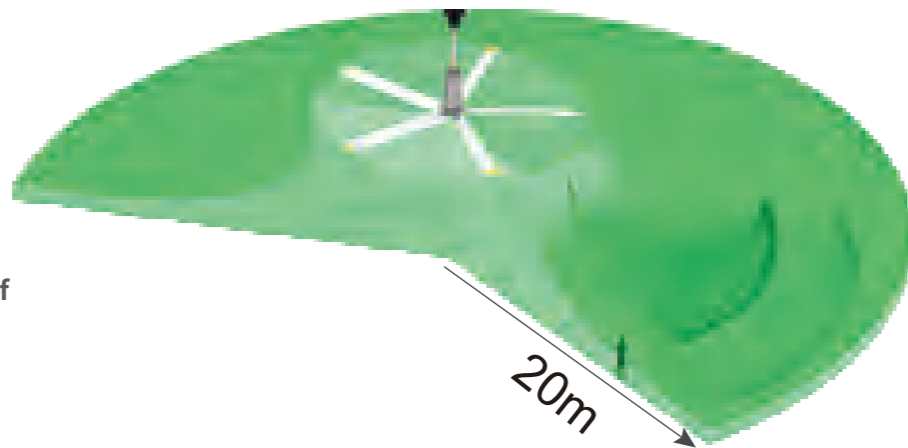

Product Function

Personnel Cooling

The Industrial fan produces a natural breeze to blow the surface of the body, evaporate sweat, and take away the heat to cool down. The cooling feeling can reach 4-7°C.

Natural Ventilation

The ventilation solutions such as small fans, air conditioners, and exhaust fans are subject to many restrictions in tall and wide enclosed space, while large Industrial HVLS fans can effectively enhance the orderly movement of the airflow field, promote air mixing, improve air quality and at the same time can match with air conditioners and exhaust fan together to get better ventilation and cooling effect.

Dehumidification & Moisture-Proof

Industrial fans promote air mixing in the entire space, so that the gas inside can be well dissipated, thereby improving the air quality of the entire room and obtaining a healthy, dry and safe working environment.



Energy-Saving & Environmental Protection

Compared with central air conditioners, water air conditioners, small fans and cooling equipment, permanent magnet direct drive industrial fans have lower energy consumption, longer life, lower maintenance costs, no pollutants generated during operation, and very good energy saving and environmental protection effect.

Advantages



High Safety Factor

Multiple safety protection measure to ensure safe installation and use independent invention patent: the casing and shaft is suspended with separate hanging structure, double anti-loosening, independent suspension inside and outside, floor anti-loose pad + rubber pad, double anti-loosening.

In the event of a sudden power failure, the fan blades do free inertial motion, stop slowly, and will not suddenly lock up, avoiding the risk of fan blades falling off and breaking.

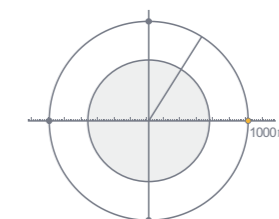

Wide Covering Area

Giant diameter (7.3 meters) and low speed can promote the orderly flow of air in a wide range, and the effective coverage area is 800-1500 m².



Maintenance Free

Permanent magnet direct-drive outer rotor motor is lifetime maintenance free, which can save maintenance costs.

Industrial HVLS Ceiling Fan(Outer Rotor PMSM)



Parameters

Model	Diameter (MM)	Blades (PCS)	Weight (KG)	Voltage (V)	Frequency (Hz)	Current (A)	Power (KW)	Max. Speed (RPM)	Max. Air Volume (m ³ /min)	Coverage (m ²)
WF5OPM73	7300	5	100	380/220	60/50	2.6/4.5	1.2	10-55	14950	1500 (理论上 1800)
WF5OPM61	6100	5	95	380/220	60/50	2.6/3.8	1.0	10-60	12000	1200

Introduction

1. High energy saving: The weight and thickness of the motor are further reduced, making the ceiling fan host thinner and lighter.
2. High cost performance: While ensuring high energy efficiency and high reliability, it has a higher cost performance.
3. Large torque: Compared with the inner rotor motor, the outer rotor direct drive force arm is longer and the torque is greater. The unique outer rotor torque design combines cutting-edge technologies in mechanical design, electromagnetic design, thermal design and other comprehensive disciplines to design the motor into a structure with high efficiency, small size, light weight, low noise and high reliability; Wanshsin masters the core technology (Permanent magnet brushless motor and drive integration), providing customers with high-stability products.

14950

Max. air volume (m³/min)

55

Max. speed (RPM)

1.2

Rate power (KW)

20%+

Annual electricity savings



Parameters

Model	Diameter (MM)	Blades (PCS)	Weight (KG)	Voltage (V)	Current (A)	Power (KW)	Max. Speed (RPM)	Max. Air Volume (m ³ /min)	Coverage (m ²)
WF5OPM50	5000	5	75	220	2.0	0.6	75	9800	900
WF5OPM38	3800	5	55	220	1.5	0.35	100	8000	720
WF5OPM30	3000	5	40	220	0.9	0.25	120	6000	300
WF5OPM24	2400	5	35	220	0.8	0.2	150	5000	200

Introduction

1. Lighter weight
2. Large torque
3. High energy saving
4. High air volume
5. Gentle wind

9800

Max. air volume (m³/min)

150

Max. speed (RPM)

0.6

Rate power (KW)

20%+

Annual electricity savings

Outer Rotor PMSM(Permanent Magnet Synchronous Motor)

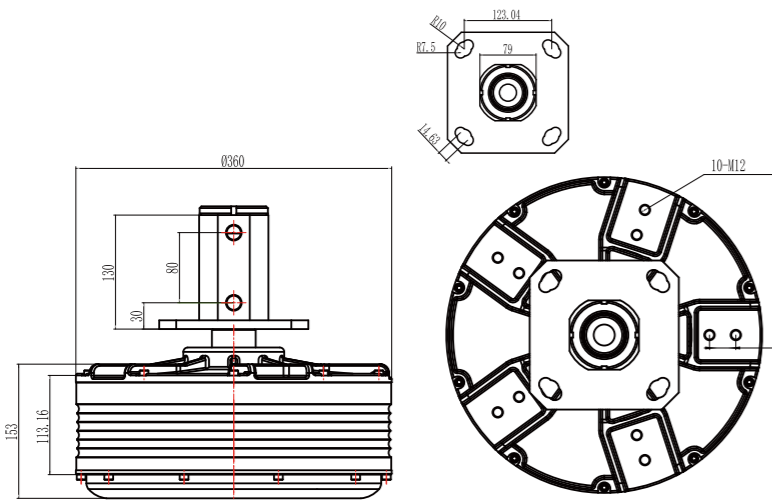

Parameters	
Voltage (VAC)	380
Power (KW)	1.2
Current (A)	2.6
Noise (dB)	≤40
speed (r/min)	10-55
Protection Level	IP44/IP55
Insulation Grade	F



1 Compact size

The overall structure is made into a flat structure, which is smaller in size and 60% lower than the height of traditional motors. The height of the outer rotor main unit is only 0.12M, making it easy to apply in various small spaces.



2 More Reliable

Independent wheel hub mounting method, safe and reliable. The high retentivity magnetic steel and card slot fixing design prevent the magnets from demagnetizing or falling off; the fan blade connection end is supported by double bearings, which ensures smoother operation, low vibration, and long life.



3 More Energy Efficient

Super performance and efficiency, motor efficiency is as high as 84%. It reaches the national first-level energy efficiency standard and saves more than 20% of electricity compared with the asynchronous motor + reduction gearbox industrial ceiling fan of the same specification.

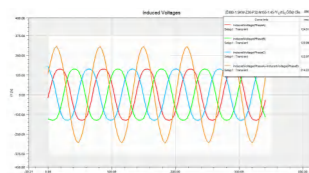

4 Low Noise

Noise levels are lower. Using the optimal number of slot poles and unequal air gaps, the sinusoidal air gap waveform and cogging torque are optimized to reduce the motor noise index to below 40dB.

5 Maintenance-Free

The permanent magnet direct drive motor has no reduction mechanism and does not need to change the lubricating oil regularly. In addition, the motor has low vibration and low temperature rise design, making the motor truly maintenance-free.

Since the heat source of the outer rotor structure is located on the inner layer of the main unit, it is more difficult to dissipate heat than the inner rotor. It is necessary to design heat dissipation slots to conduct internal heat away to ensure low temperature rise and long service life. Compared with the inner rotor structure, its protective properties are slightly worse, suitable for various low-noise, relatively closed places such as factories, shopping malls, and reading halls.

Control System

Control system - intelligent inverter

The drive motor and drive controller are designed in an integrated manner, with better parameter matching, lower motor electromagnetic noise and better operation stability.

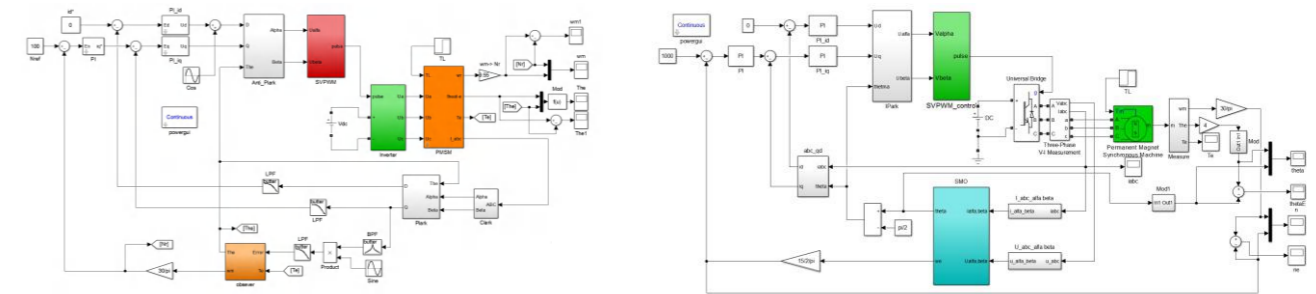

A dust-proof net and a groove at the bottom of the box are added to the control cabinet to ensure that water, oil and other liquid contaminants can be discharged from the grooves on their own. The surface of the control circuit board is coated with conformal anti-paint and a layer of acrylic board is added to enhance the anti-interference and corrosion resistance of circuit boards.

Guide rail troughs are installed in the cabinet, and the electrical circuit layout is clear, neat and stable, which can prevent instability caused by external factors and ensure the efficiency and stability of the control cabinet.

Advantages

1. Built-in overload & overcurrent protection, which can automatically cut off the power supply when an accident occurs, thereby ensuring the safety of industrial fans in large factories. Simple and user-friendly control panel settings, convenient and clear to use.
2. Open-phase protection: Built-in open-phase protection prevents the inverter from shutting down immediately when a certain coil is not energized to prevent the motor from burning out.
3. Noise control: debug the driver output power waveform to the best, reduce peak waveforms, match the best carrier parameters, and debug electromagnetic noise to the best state.
4. Multiple expansion functions (touch screen, time controller, modular control).



Safety Guarantee

1.Design of six major safety components

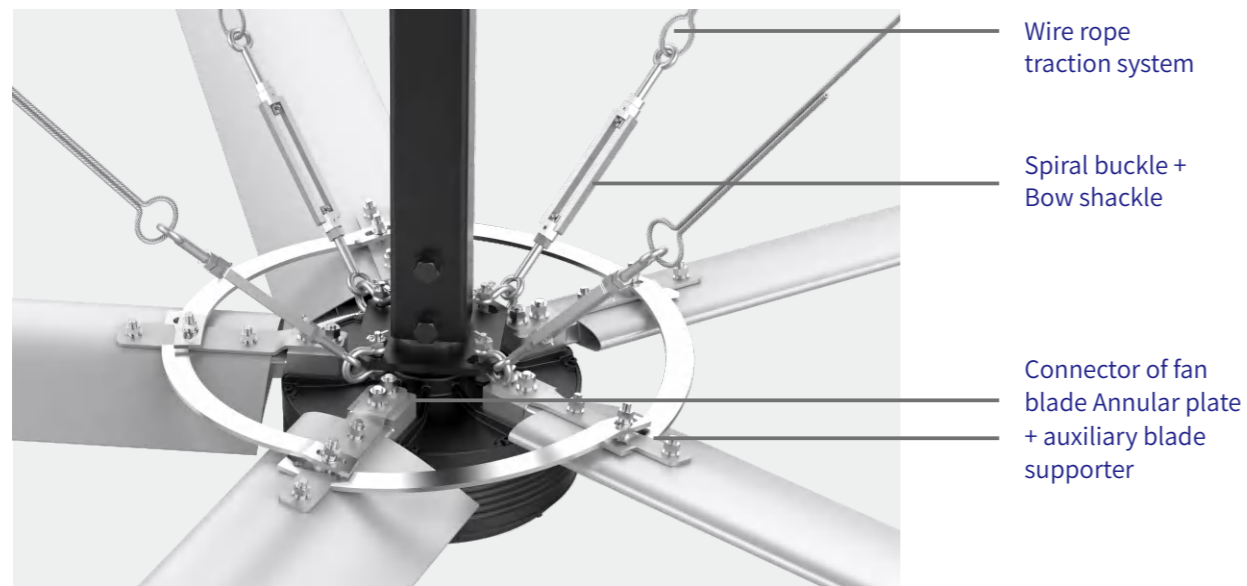

Safety componets	Description
Wire rope traction system	Ensure the balance of the main body and ensure the main body will not fall under external forces. The stress intensity of each steel wire cable: reach 1000 KG.
Spiral buckle + Bow shackle	Avoid the risk of loose wire rope decoupling intraditional hook structures. Providing more safety assurance.
Annular plate + auxiliary blade supporter	Ensure that the fan blade will not fall and fly out if the main supporter of the fan blade break sunder external force.
Connector	The main safety components of the fan toensure the safety of the fan' s long-term operation. Material: Aluminium 6061-T6 Processing: Forged and CNC precision.
Fasteners	Grade of fasteners: 12.9. All fasteners will be tightened after installation to ensure that they will not loosen permanently.
Controlling system	Automatically alarm and slowly stop operation for protection in the event of anaccident or over load of the wind mill.

2.Safety Installation

- 01** Customized Installation Plan
- 02** Scientific & Concise Installation Process
- 03** Experienced In Level, Height, Balance
- 04** Fasteners Have Torque Standards For Optimal Tightening

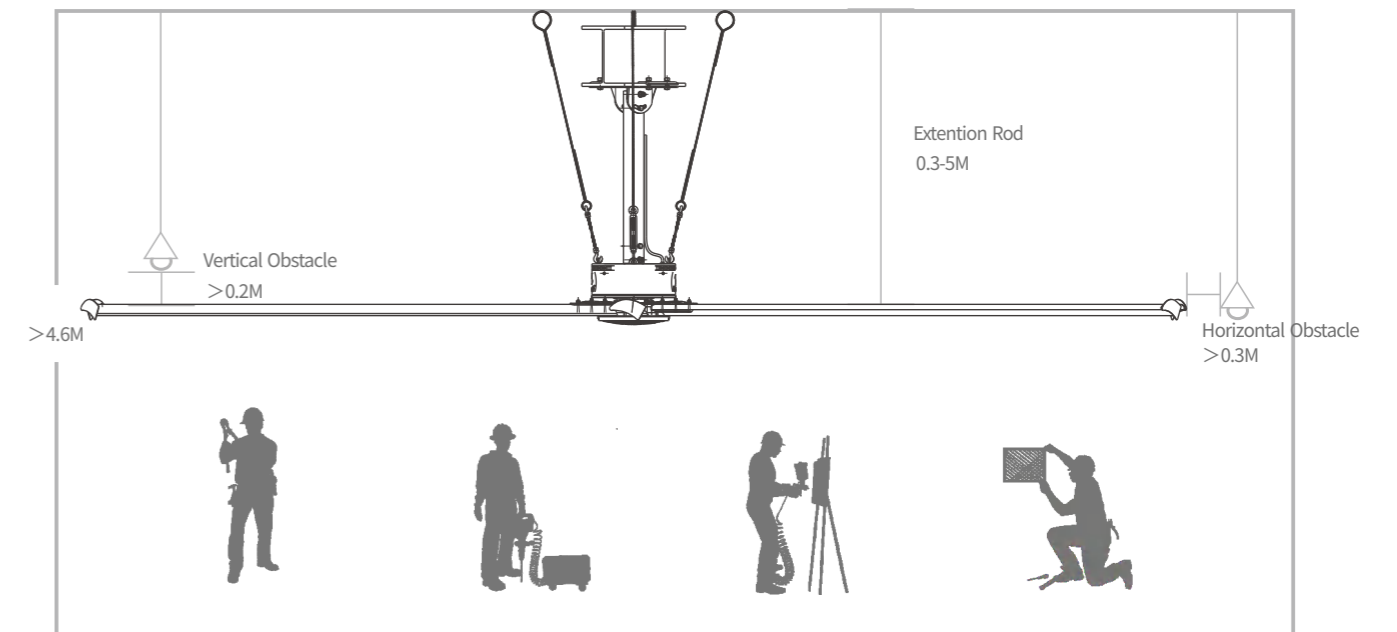

Installation Conditions

- Fan blade distance from the ground >3m
- Fan blade dstance from obstacles like crane >0.3m
- Blade end distance from obstacles like column, light >0.3m
- Any complex structure such as steel structure, concrete structure, spherical grid structure can be installed
- Special installation places are installed after modification according to the site

3.Security Debugging

The control cabinet safety alarm device has built-in overload and phase loss protection, which can send out alarm signals in time to ensure safe operation.

Blade safety connection piece, shaft connection protection plate.

Fasteners have torque standards for optimal fastening and anti-loosening structure.

On-site commissioning and testing to ensure the customer's installation effect.



Control Cabinet Safety Alarm Setting

4.Security

Strictly abide by the quality management system standards and complete the test report.

100% full inspection of specifications, parameters and noise of the delivered product, and the quality standards are consistent with international standards.

2 years warranty for whole unit.

Any problems, the after-sales department will respond within 24 hours.

OEM and ODM serviced are warmly welcome.



Quality Management System Certification



Safety Test Report

Installation of PMSM Industrial HVLS Ceiling Fan(Outer Rotor)

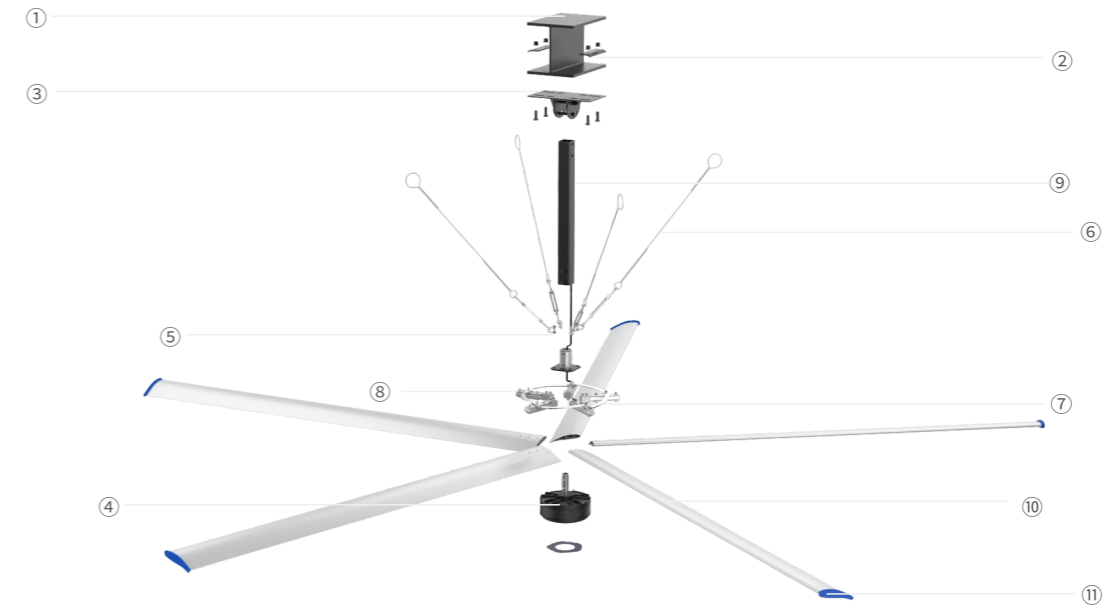

- ① I beam
- ② Beam pressing plate
- ③ Mounting plate
- ④ PMSM
- ⑤ Turnbuckle
- ⑥ Stainless steel wire
- ⑦ Round plate
- ⑧ Connector of fan blades
- ⑨ Supporter
- ⑩ Fan blade
- ⑪ Fan blade tails

Installation steps:

1. Use M18 bolts to securely connect the I beam(1) to the Beam pressing plate(2) and Mounting plate(3). Then fix the upper end of the Supporter(9) to the Mounting plate(3) through bolts.
2. Use M18 bolts to securely connect the top stator sleeve of PMSM(4) to the lower end of Supporter(9).
3. Use a level tester to adjust PMSM (4) so that PMSM (4) and I beam (1) remain level.
4. Connect the 4 Turnbuckles (5) to the four lifting holes on the top suspension plate of the PMSM (4), then use 4 wire ropes (6) to pull the 4 Turnbuckles (5) at one end and fix the other end to the surrounding I beam (1)
5. Insert the 5 connector of fan blades (8) into the 5 fan blades (10), install the Auxiliary support plate and pre-tighten it with M10 bolts and lock nuts, and install the Fan blade tails (11) at the end of the blades. And fix it with M5 bolts and nuts. Complete fan blade installation
6. Install the assembled blade assembly into the 5 slots on the upper end cover of PMSM (4), and secure it with M12 loosening nuts and the reserved bolts in the slots;
7. Unscrew the nuts of the middle bolts connecting the connector of fan blades (8) and Fan blades (10), use the Round plate (7) to connect and fix the five connector of fan blades (8), and tighten the pre-fixed screws in step 5. Tight link bolts;
8. All fixing bolts must be coated with bolt locking glue before tightening.

Optional Accessories

In addition to supplying complete machines we also provide you with a wide range of industrial HVLS fan parts, including motor, blade, controller, etc. At the same time, you can also customize the fan according to your needs and purchase parts separately to upgrade your fan.



PMSM Motor
(Outer Rotor)



Mounting Plate



Turn Buckle +
Bow Shackle



Beam Pressing Plate

The outer surface of the parts is galvanized, and the anti-corrosion and anti-rust capabilities are far greater than the spray painting process of ordinary manufacturers.



Main connector of fan blade
Made of aviation aluminum
(6061), forging process.



Fan blade with tails
The blades are made of aviation aluminum alloy (6063-T6), with internal rib design and unique aerodynamic blade airfoil design.



Round plate



Safety wire connection bolt



VFD

Structure

The blade structure is independently developed, making it more scientific and efficient. (Joined with the R&D team of senior doctoral supervisors from 985 colleges and universities, we independently developed and designed the blade cross-section shape and installation angle, making the fan more energy-saving and efficient when working, with a larger air volume)

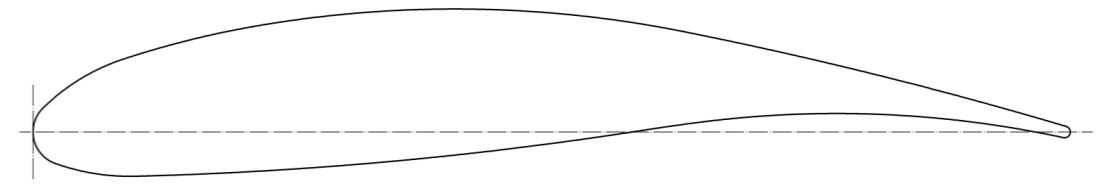

The key structural parts are designed with unlimited lifespan to ensure that the product can be used for a long time without failure.

After analysis and calculation, under 1.5 times the load, key structural parts such as the connector of fan blades (material 6061-T6, maximum stress 53.11MPa), fan blades (material 6063-T6, maximum stress 38.96MPa) have reached infinite life.

(Note: According to the material life-frequency curve, any frequency segment of the stress calculated through analysis is below the curve, that is, under this stress condition, it can work with unlimited frequency and the product life is unlimited)

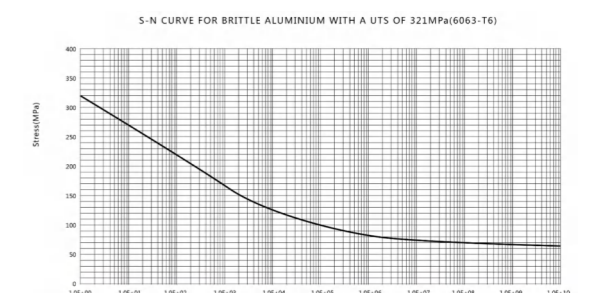
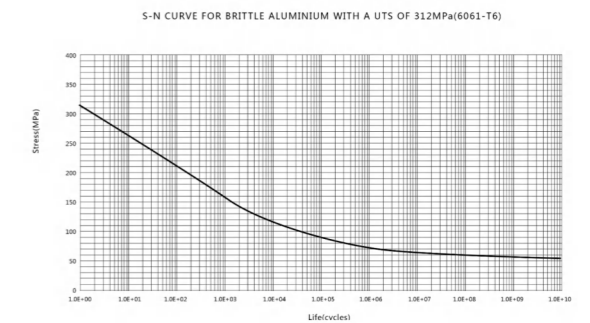
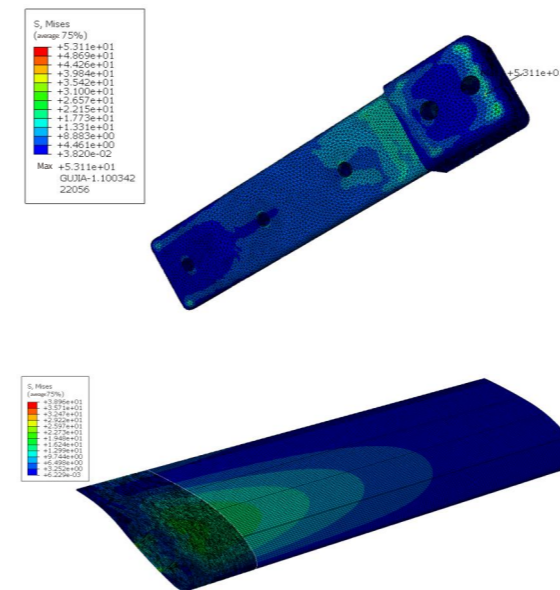

Applications

Case 1

SANY Intelligent Factory:



Factory Area:

100000M²

Installation Structure:

I-Beam construction Mesh Construction

Model:

WF5PM73 PMSM HVLS Fan



Case 3

SINOBOOM Lift Car Workshop:



Factory Area:

100000M²

Installation Structure:

I-Beam construction Mesh Construction

Model:

WFGEG73 Geared HVLS Fan



Case 2

TRUKING Medical Workshop:



Factory Area:

300000M²

Installation Structure:

I-Beam

Model:

WF5PM73 PMSM HVLS Fan



WANSHSIN Factory

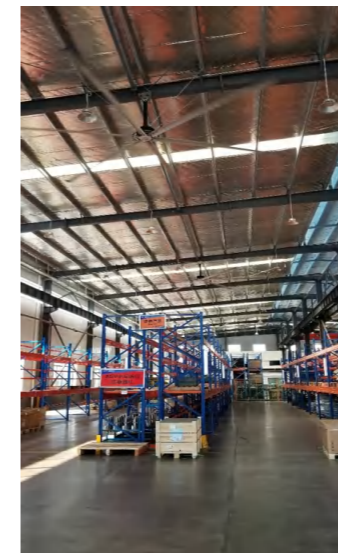

Warehouse



Assembly line



CNC workshop

PMSM Exhaust Fan



Product Parameters

Model No.	WX-PMSM-1-037	WX-PMSM-1-055	WX-PMSM-1-075	WX-PMSM-1-110
Blade diameter(mm)	860mm	1060mm	1260mm	1420mm
Airvolumn(m ³ /H)	22000(M ³ /H)	32000(M ³ /H)	40000(M ³ /H)	50000(M ³ /H)
Rated power(W)	375W	550W	750W	1.1kw
Rated voltage(V)	220/380V	220/380V	220/380V	220/380V
Height(mm)	860mm	1060mm	1260mm	1460mm
Width(mm)	860mm	1060mm	1260mm	1460mm
Thickness(mm)	560mm	560mm	560mm	580mm

DC Brushless Permanent Magnet Motor

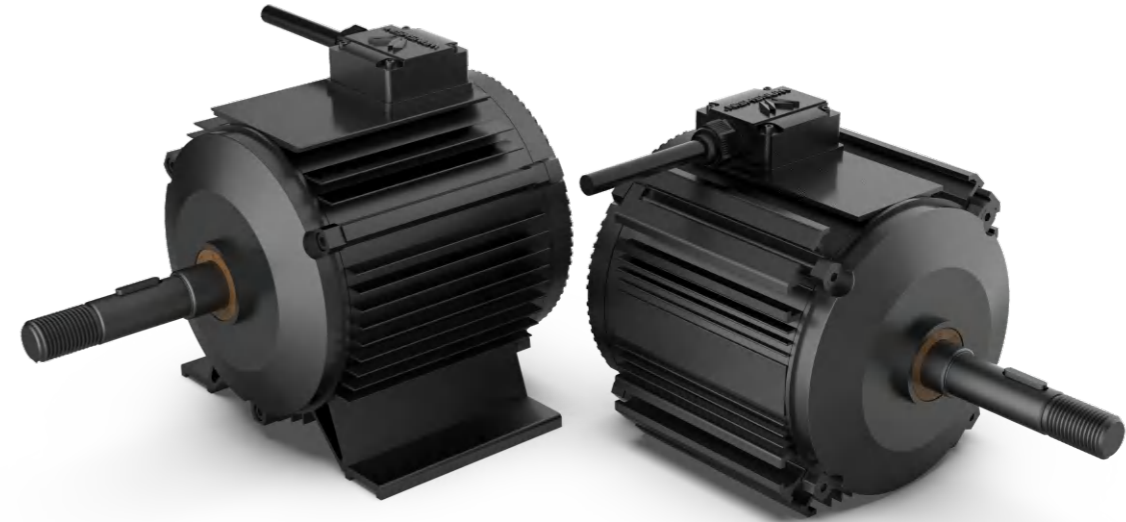

Motor Characteristics

- Waterproof, sealed, household appearance design, high protection level;
- High efficiency, ultra-low energy consumption design, 30 to 50% energy saving than Asynchronous motor ;
- Long life, low noise, maintenance-free, high reliability design;
- Low speed, high torque, no blind point quick start, stable load operation;
- variety of operating modes, large speed range, remote speed control;
- Motor and driver integration design, function, speed regulation, operation and installation is simple.

Rated voltage V/Hz	Rated Voltage (V)	Rated power (W)	Rated torque (N.M)	Rated speed (RPM)	Speed range (RPM)	工作方式 (/)	Insulation grade (IP)	Protection grade (IP)
WX-PMSM-1-037	220/380V	375	3.7	960	/	S1	F	65
WX-PMSM-1-055	220/380V	550	7.5	700	/	S1	F	65
WX-PMSM-1-075	220/380V	750	12	600	/	S1	F	65
WX-PMSM-1-110	220/380V	1100	23	450	/	S1	F	65
WX-PMSM-1-037-T	220/380V	375	3.7	960	200-960	S1	F	65
WX-PMSM-1-055-T	220/380V	550	7.5	700	200-700	S1	F	65
WX-PMSM-1-075-T	220/380V	750	12	600	200-600	S1	F	65
WX-PMSM-1-110-T	220/380V	1100	23	450	200-450	S1	F	65

- W/T:adjustable speed; W/OT:fixed speed

Product Performance Characteristics

- Bell mouth design is characterized by low noise, large air volume, strong wind pumping, high efficiency and low cost
- Imported bearing, high strength, low noise, durable
- PVC shutter or aluminum shutter SYNTHESIZED by the principle of air flow, anti-oxidation, light weight, no deformation, flexible opening, Prevent air from flowing back
- Direct drive motor shaft directly lock vane disc, high stability strength, good toughness, low failure rate
- Plastic steel blade, no deformation, no fracture, attractive and durable

Product features

- **Energy saving** : less power consumption, only about 10%-15% power of traditional air conditioners
- **Environmental protection** : Freon-free (CFC)
- **Fast cooling effect** : after the outside air enters the room through the cooling water, the indoor temperature on the cooling water curtain side can reduce 5-10 degrees
- **Fast exhaust speed** : hot and odorous air is replaced and exhausted outdoors
- **Effective control of environment** : different wind speeds result in a cool wind effect, making people feel unusually comfortable and refreshing
- **Effectively prevent the spread of sudden influenza disease** : birds, mosquitoes, flies are vectors of infectious diseases, since the water curtain ventilation system is sealed by negative pressure, it will reduce the probability of the spread of disease vectors, allowing the staff to work in a comfortable, safe and secure environment.
- **High efficiency and energy saving** : saving about 3000kWh electricity per fan per year

Applications

It is suitable for workshops with high temperature or unpleasant odor, such as heat treatment plants, casting plants, aluminum factories, shoe factories, leather goods factories, electroplating factories, various chemical factories, etc.

In an independent space, such as a factory building or a pipeline, a negative-pressure air fan or other air extractor device is installed at one end of it to generate air flows in and out, which causes a negative pressure, the forward air supply is called positive pressure. Negative pressure can discharge the hot air, odor and dust out of the factory. To create air convection in independent spaces, the total volume, total area, wind speed per second and air changes per hour of the plant need to be accurately calculated except the exhaust equipment.

Applications

- Remove excess heat in the workshop timely
- Remove the exhaust gas and unpleasant odor in time
- Prevent the build-up of influenza virus efficiently
- Increase oxygen rate thus improve work efficiency and production capacity
- Remove excess moisture to reduce the erosion of equipment and the discomfort of personnel
- Remove the smoke and dust in the workshop in time

